

SAFE DESIGN FOR HOT DIP GALVANIZING

YOUR CONCERNS ARE OUR CONCERNS

At Premier Galvanizing, your concerns are our concerns. That's why we'll always go out of our way to offer advice on any subject you're concerned about. This poster deals with some of the most important questions our customers have raised in the past but please feel free to ask us for further clarification on these or any other issues.

! NONE OF THE ADVICE CONTAINED WITHIN THIS POSTER WILL BE EFFECTIVE, AND MAY ENDANGER LIFE, IF ANY OBSTRUCTION, SUCH AS TIMBER, CANS, FOOD PACKETS OR EXCESSIVE SHOT/SWAF, IS LEFT IN THE HOLLOW SECTION – PLEASE CHECK BEFORE FABRICATION.

VENTING REQUIREMENTS

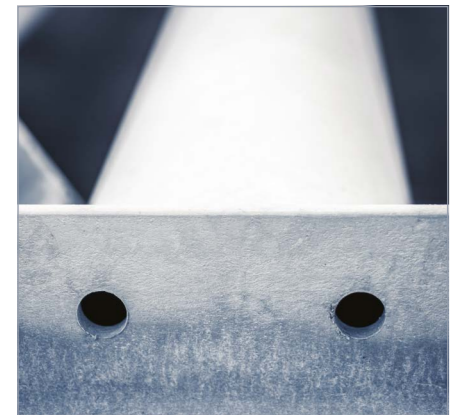

Suitably-sized vent holes. The photo shows how large structural hollow section members should have suitably-sized vent holes, as well as holes on the opposite side.

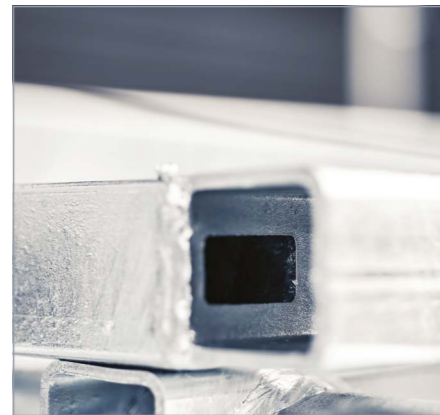

Internal venting. Before welding on the SHS leg, create internal flow by venting the main RHS member in appropriate places, as per the photo.



End plate venting. This is how a hollow section end plate should be cropped at all corners prior to attaching to prevent zinc and air traps.



Overlapping surfaces. Leave minimum gap of 2mm between overlapping surfaces. Where seal welding is not practicable stitch welding should be used.



Air lock prevention. The photo shows how stopping short the end plate prevents an air lock.



Zinc free flow. Stopping short cross beams eliminates air locks and allows free flow of zinc through the fabrication.



External venting in hollow section frames. The photo shows a RHS fabrication. The hole size is adequate.

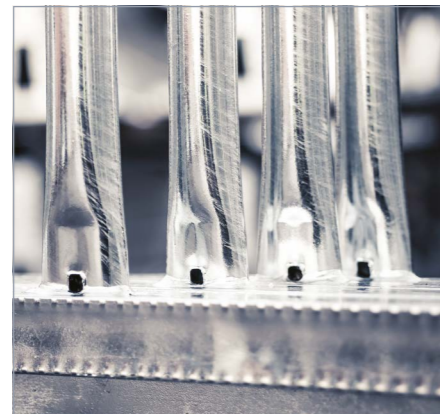

External venting in hollow frames. Note how the holes drilled close to the point of insertion will prevent air locks and zinc traps.



Hole stamping. Holes stamped out prior to weld assembly.

THE IMPORTANCE OF VENTING AND DRAINAGE

To ensure the safety of our employees and achieve the best quality zinc coating, it is important to ensure that during immersion in the galvanizing bath, superheated air can escape all internal spaces and the molten zinc can flow freely over all surfaces, external and internal. So, where there are sealed hollow sections or cavities, vent and drain holes are essential, otherwise serious injuries to our personnel may result.

When adequately sized and correctly located, these holes will:

- Significantly reduce the risk of injury to our galvanizing operatives.
- Allow faster immersion and withdrawal speeds which will help to minimise excessive coating build-up and reduce the risk of distortion by minimising temperature differentials.
- Virtually eliminate the risk of damage to product, plant and equipment caused by the explosive vapourisation of entrapped moisture.
- Improve the characteristics of the galvanized coating by restricting the effects of zinc solidification during drainage and reduce the mass of zinc required to achieve a good finish.

Overall, a correctly vented product will ensure the safety of our operatives, total corrosion protection, produce an optimum quality finish and reduce customers' costs.

RECOMMENDED SIZE AND LOCATION OF VENT AND DRAIN HOLES FOR HOLLOW SECTIONS

Table 1

Section cross-sectional shape and dimensions (mm)		Number and location of holes or crops at each end of the hollow section											
		1 hole	1 hole	2 holes	2 holes	2 crops at corners	4 holes	4 holes	4 crops at corners	4 holes of 15mm + 1 central hole	4 holes of 15mm + 1 central hole	4 crops at corners of 25mm + 1 central hole	
Round	Square	Rectangular	Diameter of hole (mm)		Size of crop (mm)	Diameter of hole (mm)		Size of crop (mm)	Diameter of central hole (mm)				
15	15	—	10	10	—	—	—	—	—	—	—	—	
20	20	30 x 15	10	10	—	—	—	—	—	—	—	—	
30	30	40 x 20	—	—	10	10	—	—	—	—	—	—	
40	40	50 x 30	—	—	12	12	10	—	—	—	—	—	
50	50	60 x 40	—	—	—	—	10	10	—	—	—	—	
60	60	80 x 40	—	—	—	—	10	10	12	—	—	—	
80	80	100 x 60	—	—	—	—	12	12	15	—	—	—	
100	100	120 x 80	—	—	—	—	14	15	20	—	—	—	
120	120	160 x 80	—	—	—	—	20	20	25	—	—	—	
160	160	200 x 120	—	—	—	—	25	20	30	35	—	—	
200	200	260 x 140	—	—	—	—	30	25	35	50	40	—	
300	300	350 x 250	—	—	—	—	45	40	55	80	70	75	
400	400	450 x 250	—	—	—	—	60	50	75	110	100	110	
500	500	600 x 300	—	—	—	—	75	65	90	140	125	135	
600	600	700 x 400	—	—	—	—	85	75	110	170	150	165	

Note 1: The shaded holes or crops indicate the hole or crop in the opposite end of the hollow section.

Note 2: The size of crop given in this table refers to the length of the adjacent side (not the diagonal length).

Note 3: Table entries that are not applicable are designated by "—".

COLUMNS, BEAMS AND CHANNEL SECTIONS

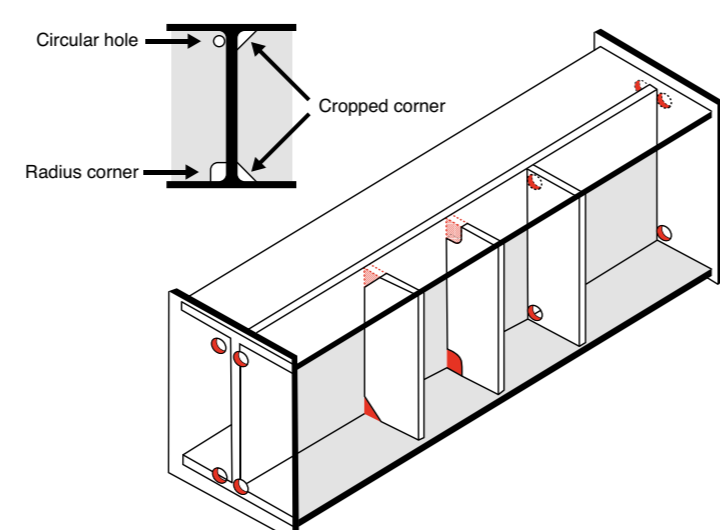

Fig. 1

External stiffeners, welded gussets, webs on columns and beams, and gussets in channel sections should always have corners cropped. Gaps created should be as large as possible without compromising on strength. If welding is required around the edge, a radiused corner will facilitate the continuity of weld around the cut end to the other side. Circular holes are less effective but, if used, should be as close as possible to the corners and edges.

Ask us about the best vent and drainage hole sizes. We are happy to help.

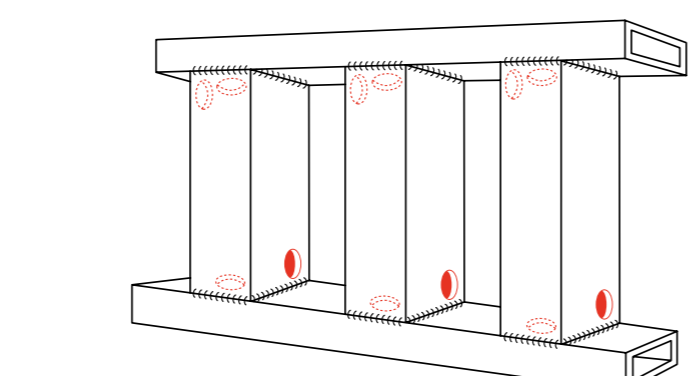

Fig. 2

On structural hollow sections, provision must be made for venting and draining.

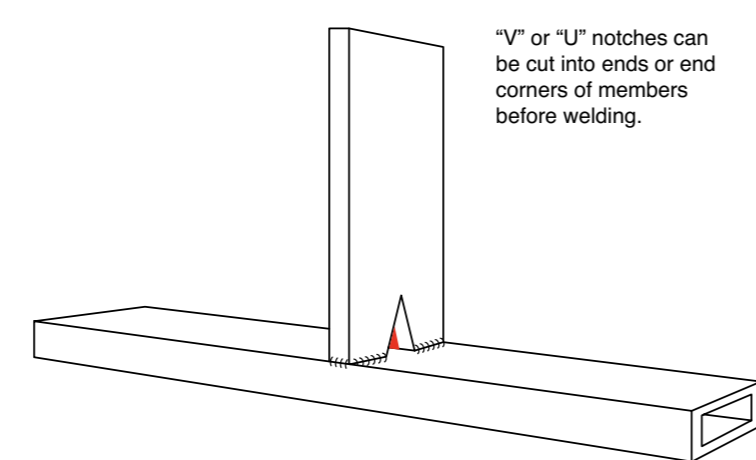

Fig. 3

With vertical members, drilled holes or V notches should be provided, diagonally opposite each other, at top and bottom.

OVERLAPPING SURFACES

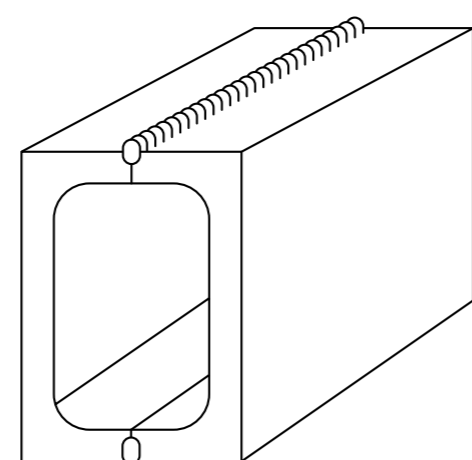

Fig. 4

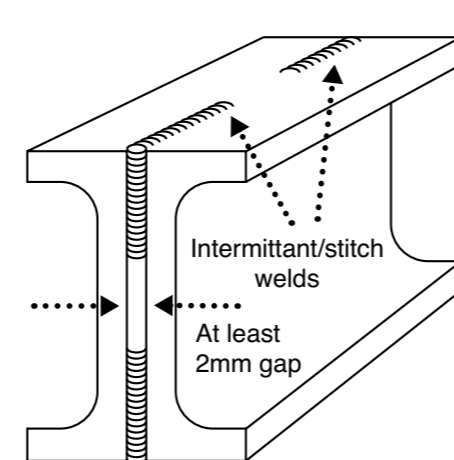

Fig. 5

Overlapping surfaces. There should be a minimum gap of at least 2mm between plates, overlapping surfaces and back-to-back angles and channels (figs. 5 & 6). When small overlaps are unavoidable, seal edges by welding (fig. 4). Where seal welding is not practical, temporary surface staining in crevices may be apparent after galvanizing and quenching. Clean with a bristle brush and mild detergent. Crevices can be sealed after galvanizing with a suitable sealant.

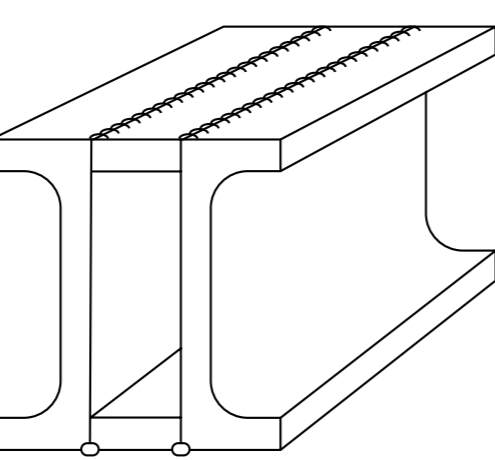

Fig. 6

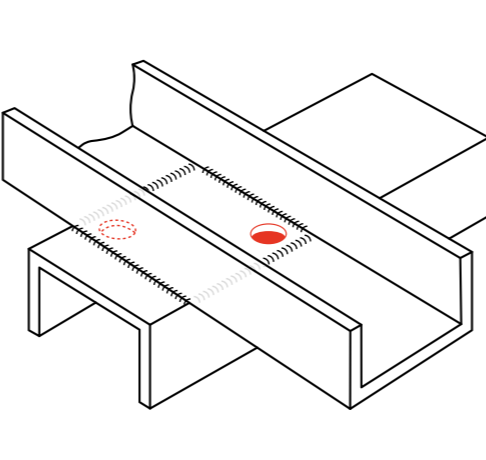

Fig. 7

Larger overlapping surfaces. If contacting surfaces are unavoidable, where the overlapping area is greater than 100cm², two holes in diagonally opposite corners of the overlapping area are required. Ideally, holes should be drilled through both pieces in contact to assist the free flow of liquid (fig. 7). Hole diameter must be a minimum of 12mm or at least the same size as the steel thickness, whichever is greater. Hole requirement can be avoided by stitch welding the overlapping areas. The holes required are to ensure the safety of our employees and help us deliver the best possible quality galvanized coating. Where the overlapping area is greater than 1000cm² advice should be taken from the galvanizer.

PIPES AND TUBULAR FABRICATIONS

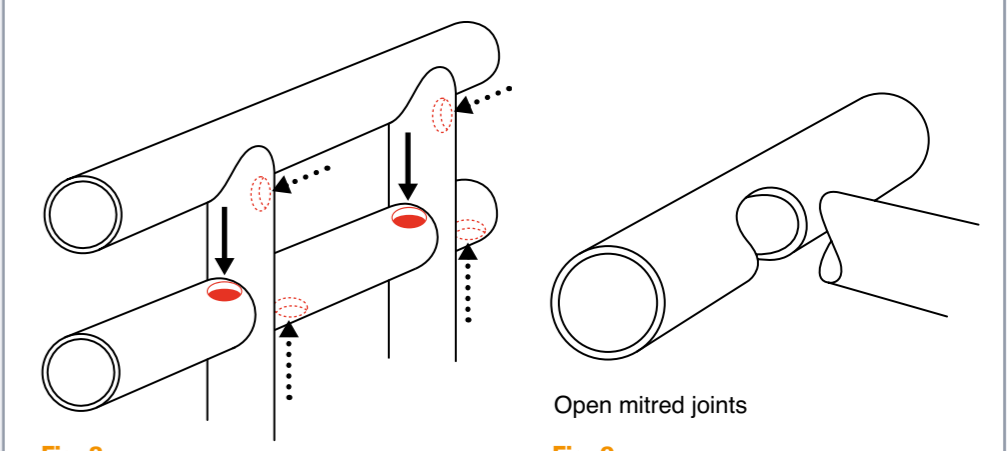

Fig. 8

Fig. 9

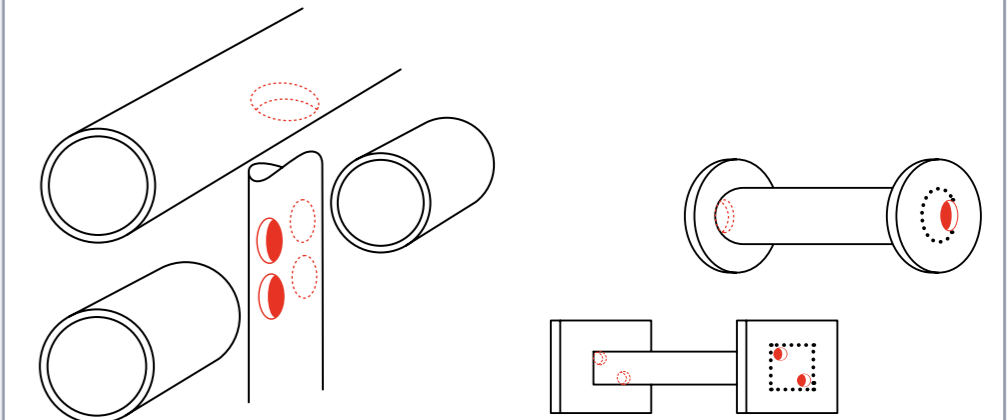

Fig. 10

Fig. 11

! Holes 20mm diameter or larger (Please consult in all instances relating to internal venting)

Welded pipe sections. Closed sections must never be incorporated. External holes may be positioned (as in fig. 8), enabling our galvanizing experts to make a quick visual inspection to ensure the work is safe to galvanize. Sections can be interconnected using open mitred joints (as in fig. 9), or interconnecting holes drilled before fabrication (as in fig. 10). Pipe ends can be left open or plugged after galvanizing (see unwanted vent holes below).

Small tubular fabrications. Small tubular fabrications must be vented, preferably with holes not less than 10mm in diameter.

Unwanted vent holes. May be closed by hammering in aluminium or plastic plugs after galvanizing and filing off flush with surrounding surfaces.

Tubular fabrications/hollow structures. Drain/vent hole sizes should be preferably 25% of internal diameter or diagonal dimension for sections yielding a maximum cross section area 180cm². The percentage can depend on the shape of the fabrication. We recommend that you consult with a Premier Galvanizing galvanizer at the design stage.

COLUMNS, TANKS AND WELDED JOINTS

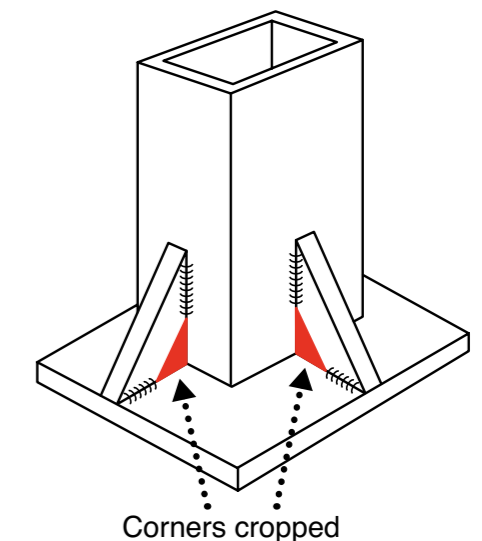

Fig. 12

Welded strengthening gussets and webs on columns and beams, and strengthening gussets in members fabricated from the channel of I-beam sections should have corners cropped or holed (figs. 1 and 12) to prevent air being trapped in pockets and corners, allowing cleaning solutions and molten zinc access to the entire surface area and facilitating drainage.

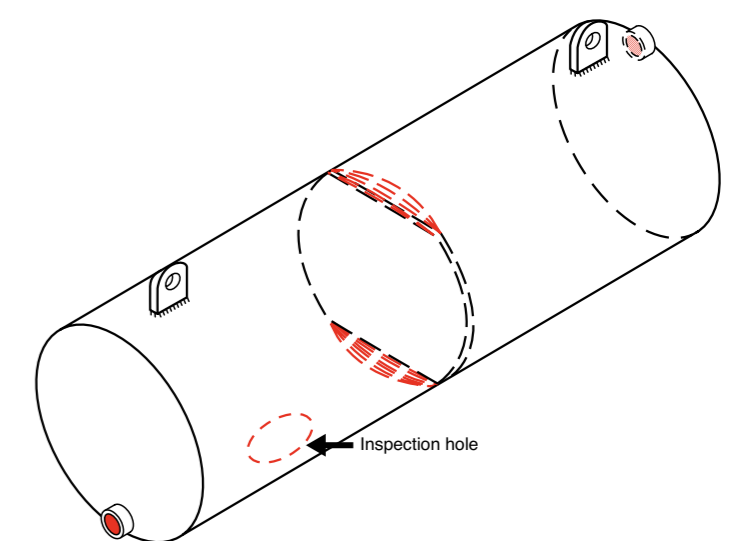

Fig. 13

For tanks, vents should be diametrically opposite and at least 50mm in diameter. Internal baffles should be cropped top and bottom. Lifting lugs required as indicated. Baffles to be viewable through vent holes or an inspection hole. Contact us to discuss the position of the inspection hole.

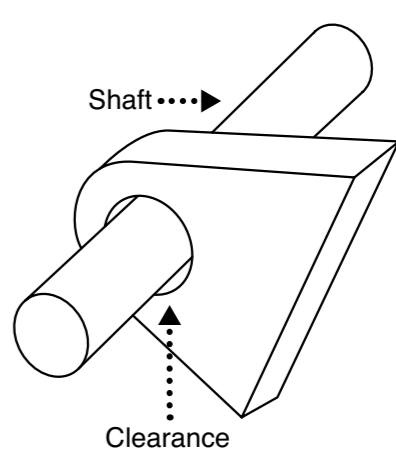

Fig. 14

Clearance for moving parts. Drop handles, hinges, shackles, shafts and spindles require minimum radial clearance to allow for thickness of galvanized coating (see also Table 2).

Table 2

Shaft of spindle size	Min. radial clearance
Up to 30mm diameter	2.0mm
Over 30mm diameter	2.5mm

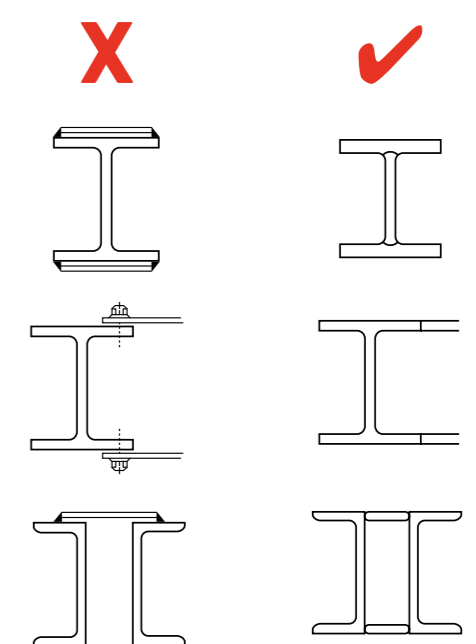

Fig. 15

Welded joints should be continuous if not enclosing an otherwise unvented surface. Bolted joints best made after galvanizing.

WE ARE HERE TO HELP

Our Technical Support Team is available to answer any queries through the galvanizing process from design to end of life and are happy to attend to consult with design staff, carry out site inspections and provide technical advice and to eradicate instances of bath zinc explosions as per this image.

For technical advice please contact us on:

Premier Galvanizing Corby
Darwin Road
Willowbrook Industrial Estate
Corby,
Northants, NN17 5XZ
T: 01536 409818
info@premiergalv.co.uk

Premier Galvanizing Hull
Unit 25 Stoneferry Business Park
Foster Street
Hull
East Yorkshire, HU8 8BT
T: 01482 587587
www.premiergalvanizing.co.uk

For more information visit the Joseph Ash galvanizing YouTube and watch our video "Design for galvanizing". Also you will be able to watch the consequences of zinc explosion, while galvanizing.



part of your team!